

JFW Industries, Inc.

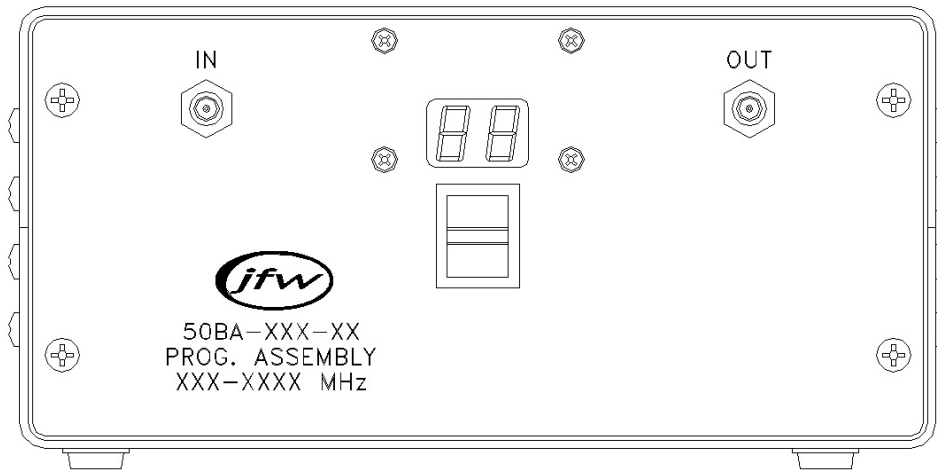

***50BA-001-63* MANUAL**

(This manual corresponds with firmware revision 0)



JFW Industries, Inc.
5134 Commerce Square Drive
Indianapolis, IN 46237
Phone (317) 887-1340
sales@jfwindustries.com

Table of Contents

<u>Section Number/Description</u>	<u>Page #</u>
1. Introduction	3
2. Manual Control	4
3. Remote Command Set	5
4. Ethernet Mode	14
5. RS-232 Mode	16
6. JFW Test Program	17
7. Scripts	20
8. FAQ's	25
Appendix A: Sample Ethernet Configuration Session	
Appendix B: Startup Information for Ethernet/RS-232 Test Systems	

Additional Documentation Provided with Operating Manual:

1. Outline Drawing
2. Specification Sheet

1. Introduction

The JFW model 50BA-001-63 test system consists of one solid state programmable attenuator that covers the frequency band 200-6000 MHz. The unit is controlled remotely via Ethernet or RS-232. The unit may be manually controlled on the front panel using the momentary switches. There is a slide switch on the back panel that allows the user to select between either Ethernet or RS-232 mode. The programmable attenuator can be set from 0 to 63dB in 1dB increments. The attenuator is set to maximum attenuation (63dB) when the unit is powered on.

In addition to this manual a CD is also provided. The CD contains the following:

- 1) 50BA-001-63 Manual.PDF.....(This Manual)
- 2) 50BA-001-63.PDF.....(Specification Sheet)
- 3) 092-6615.PDF.....(Outline Drawing)
- 4) 50BA-001-63.EXE.....(JFW Test Software)

Mechanical Specifications

The 50BA-001-63 is designed in a benchtop style enclosure. The outline drawing details all necessary package dimensions and connector layouts. The unit is AC powered via a +12V DC plug on the rear panel. A +12V DC wall transformer and standard AC power cord is supplied with the unit. The wall transformer can handle input AC voltages 100-240 VAC (47-63 Hz).

2. Manual Control

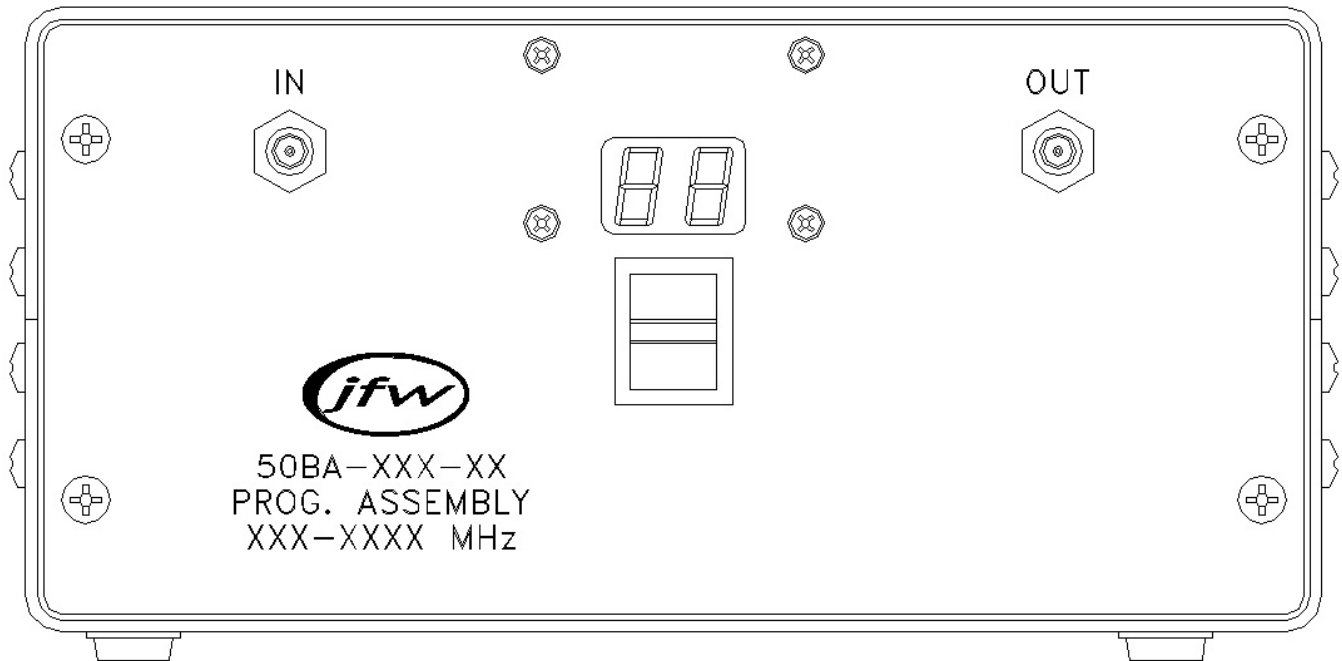

Manual control is achieved via a momentary lever actuator switch on the front panel of the unit.

The attenuation can be changed by moving the lever actuator up or down, tapping to step, or holding to jog the attenuation. Tapping will step the attenuator 1dB at a time, while holding will jog the attenuation until it reaches its limit of operation or the user releases the momentary switch.

The 7-segment LED display shows the current attenuation at all times. It is updated from any changes via Manual control or Remote commands.

Manual control is available while the unit is in either Ethernet or RS-232 Mode. Remote commands may be sent and have precedence while the attenuation is being jogged.

The speed at which the attenuators are incremented by jogging is variable via the Set Manual Speed command. A remote user may also disable the Manual Control by setting the Speed to 0.

The Speed is stored in onboard flash memory so it is restored after power cycling the unit, and has a factory default value of "5" or 50% speed.

When holding the switch in any direction, a short delay is first experienced before attenuation jogging occurs. This is normal and allows for single stepped changes to occur more naturally.

3. Remote Command Set

The following command set is used for both Ethernet mode and RS-232 mode. The command set consists of the following commands:

<u>Command</u>	<u>Page</u>
1) Identification.....	6
2) Change Baud Rate.....	6
3) Disconnect.....	6
4) Set Attenuator.....	7
5) Set Attenuator with Response.....	7
6) Read Attenuator.....	7
7) Fade Attenuator.....	8
8) Close.....	9
9) Pause.....	10
10) Message.....	11
11) Clear.....	11
12) Store.....	12
13) Recall.....	12
14) Set Manual Speed.....	13

If you send a remote commands to the unit that is not properly formatted, then you will receive one of the following error messages.

- Error1** **Command is formatted incorrectly.**
This error occurs if a command does not follow it's proper command syntax.

- Error2** **Attenuator address out of range.**
This error occurs if the attenuator address is not 1.
There is 1 programmable attenuators in this test system.

- Error3** **Attenuation value out of range.**
This error occurs when the attenuation value is not 0-63dB.
The attenuation range for this test system is 0-63dB x 1dB.

- Error4** **Interval time out of range.**
This error occurs when the interval time of the fade attenuator command is not 1-9999.

- Error5** **Interval time not properly formatted.**
This error occurs when a "M" or "S" does not follow the interval time for the fade attenuator, handover, or variable handover commands. The "M" formats the interval time to milliseconds. The "S" formats the interval time to seconds.

1) Identification Command

Syntax: IDN <CR>
<CR> = carriage return

Description: This command returns the identification information for this system and is followed by a carriage return and a line feed. It will list JFW Industries Inc, followed by the JFW model number and the firmware revision level.

Examples: *In RS-232 mode:*
IDN <CR>
“JFW Industries Inc., Model 50BA-001-63, Firmware Rev 0 <CR> <LF>”

In Ethernet mode:
IDN <CR>
“JFW Industries Inc., Model 50BA-001-63, Firmware Rev 0 <CR> <LF>”
“Current Ethernet Connections = 4 <CR> <LF>”
*

Notes: *The IDN command will also return a Message in Ethernet mode if a Message has been stored using the Message command.
To erase the message, any user can send the Clear command from Ethernet mode.
Command is not case sensitive, but must be terminated by a carriage return.

2) Change Baud Rate Command – RS-232 Only

Syntax: CBx <CR>
x = new baud rate
<CR> = carriage return

Description: This command changes the baud rate of the unit. The current baud rate is displayed on the LCD while in remote mode.

Examples: CB9600 <CR> Changes the baud rate to 9600 baud
CB19200 <CR> Changes the baud rate to 19200 baud
CB38400 <CR> Changes the baud rate to 38400 baud

Notes: “x” must be either 9600, 19200, or 38400.
Command is not case sensitive, but must be terminated by a carriage return

3) Disconnect Command

Syntax: DIS <CR>
<CR> = carriage return

Description: This command causes the test system to close the existing Ethernet connection. This command is only used while in Ethernet mode.

Examples: DIS <CR>
Returns: “50BA-001-63 Connection Closing<CR><LF>” and closes the Ethernet connection.

Notes: There must NOT be a space between the “D”, “I”, and “S”.
Command is not case sensitive, but must be terminated by a carriage return.

4) Set Attenuator Command

Syntax: SAx y <CR>
x = attenuator number to control
y = attenuation value to set the attenuator to
<CR> = carriage return

Description: This command sets attenuator “x” to “y” attenuation in dB.

Examples: SA1 0 <CR> Sets attenuator 1 to 0dB.
SA1 63 <CR> Sets attenuator 1 to 63dB.

Notes: “x” must be 1 (there is 1 total attenuator in this test system).
“y” must be 0-63 (attenuation range is 0-63dB x 1dB).
There must be a space between “x” and “y”.
Command is not case sensitive, but must be terminated by a carriage return.

5) Set Attenuator with Response Command

Syntax: SARx y <CR>
x = attenuator number to control
y = attenuation value to set the attenuator to
<CR> = carriage return

Description: This command sets attenuator “x” to “y” attenuation in dB

Examples: SAR1 0 <CR> Sets attenuator 1 to 0dB. Returns: “Atten#1 = 0dB<CR><LF>”
SAR1 63 <CR> Sets attenuator 1 to 63dB. Returns: “Atten#1 = 63dB<CR><LF>”

Notes: “x” must be 1 (there is 1 total attenuator in this test system).
“y” must be 0-63 (attenuation range is 0-63dB x 1dB).
There must be a space between “x” and “y”.
Command is not case sensitive, but must be terminated by a carriage return.

6) Read Attenuator Command

Syntax: RAx <CR>
x = attenuator number to query
<CR> = carriage return
<LF> = line feed

Description: This command returns the attenuation setting for attenuator “x”.

Examples: SA1 22 <CR> Sets attenuator 1 to 22dB.
RA1 <CR> Returns: “Atten #1 = 22dB <CR> <LF>”.

SA1 63 <CR> Sets attenuator 1 to 63dB.
RA1 <CR> Returns: “Atten #1 = 63dB <CR> <LF>”.

Notes: “x” must be 1 (there is 1 total attenuator in this test system).
Command is not case sensitive, but must be terminated by a carriage return.

7) Fade Attenuator Command

Milliseconds Interval Syntax: **FAx y z tM<CR>**

Seconds Interval Syntax: **FAx y z tS<CR>**

x = attenuator number to control

y = starting attenuation value

z = ending attenuation value

t = interval time

M = interval time format set to milliseconds

S = interval time format set to seconds

<CR> = carriage return

Description: This command fades the attenuator number “x” from “y” dB to “z” dB in “t” interval time. The intervals can be formatted to be in milliseconds or in seconds depending on if there is a “M” for milliseconds or “S” for seconds following the interval number. The fade attenuator command allows the user to fade the attenuation up or down.

Examples: **FA1 0 63 300M<CR>** Fade attenuator #1 from 0dB to 63dB in 1dB steps with 300 milliseconds between steps.

FA1 31 60 1S<CR> Fade attenuator #1 from 31dB to 60dB in 1dB steps with 1 second between steps.

FA1 55 60 1M<CR> Fade attenuator #1 from 55dB to 60dB in 1dB steps with 1 millisecond between steps.

FA1 60 7 5S<CR> Fade attenuator #1 from 60dB to 7dB in 1dB steps with 5 seconds between steps.

Feedback: At the beginning and ending of each fade attenuator command, the test system will send all connected users a message to provide feedback of the test system status. At the beginning, the message “Fade Started” is sent. When the command has finished executing, the message “Fade Finished” is sent.

Notes: This command can fade attenuation up or down.
“x” must be 1 (there is 1 total attenuator in this test system).
“y” must be 0-63 (attenuation range is 0-63dB x 1dB).
“z” must be 0-63 (attenuation range is 0-63dB x 1dB).
“y” and “z” should not be set to the same attenuation value.
“t” must be between 1 and 9999.
Command is not case sensitive, but must be terminated by a carriage return.

8) Close Command – Ethernet Only

Syntax: **CLOSE<CR>**
 <CR> = carriage return

Description: This command causes the test system to close all other user's Ethernet connections to the test system, but leaves your Ethernet connection open. This command is only used while in Ethernet mode.

Example: Four users are connected to the test system. Send an IDN to verify.

IDN<CR>

“JFW Industries Inc., Model 50BA-001-63, Firmware Rev 0<CR><LF>”

“Current Ethernet Connections = 4<CR><LF>”

CLOSE<CR>

“50BA-001-63 – 3 Connections Closing<CR><LF>”

Sending the close command will disconnect the other 3 users and leave you as the only Ethernet connection. Send an IDN to verify.

IDN<CR>

“JFW Industries Inc., Model 50BA-001-63, Firmware Rev 0<CR><LF>”

“Current Ethernet Connections = 1<CR><LF>”

The one connection that is left open is your connection.

Notes: This command is used mainly if you are running an important test and need sole access to the attenuators by closing any other Ethernet connections to the 50BA-001-63. This command is also helpful to use if you have an intermittent Ethernet connection to your network, possibly through wireless or connecting via VPN. If you lost your connection, you would then have to reconnect to the 50BA-001-63 and it would open a new socket. Sending the Close command would then close the original socket and correct the current number of connections.
Command is not case sensitive, but must be terminated by a carriage return.

9) Pause Command

Milliseconds Interval Syntax: **PAUSExM<CR>**

Seconds Interval Syntax: **PAUSExS<CR>**

x = duration of time to pause

M = interval time format set to milliseconds

S = interval time format set to seconds

<CR> = carriage return

Description: This command pauses the test system for “x” duration of time. The time duration can be set from 1-9999. The time duration can be formatted to be in milliseconds or in seconds depending on if there is a “M” for milliseconds or “S” for seconds. The pause command is useful when sending scripts to the test system and you want a timed pause between other remote commands.

Examples: **PAUSE100M<CR>** Returns: “Pause Starting<CR><LF>”
Test system pauses for 100 milliseconds.
Returns: “Pause Finished<CR><LF>”

PAUSE15S<CR> Returns: “Pause Starting<CR><LF>”
Test system pauses for 15 seconds.
Returns: “Pause Finished<CR><LF>”

Notes: Command is not case sensitive, but must be terminated by a carriage return.

Feedback: At the beginning and ending of each PAUSE command, the test system will send all connected users a message to provide feedback of the test system status. At the beginning, the message “Pause Started” is sent. When the command has finished executing, the message “Pause Finished” is sent.

Script Example: **FA1 5 2 1S<CR>** Fades attenuator #1 from 5dB to 2dB at 1 second/step.
PAUSE4000M<CR> Test system pauses for 4 seconds (4000 milliseconds).
FA1 2 5 1S<CR> Fades attenuator #1 from 2dB back to 5dB at 1 second/step.

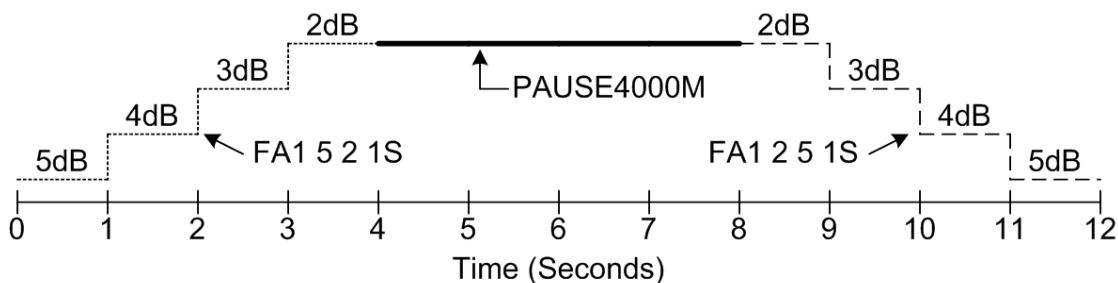

Script Notes: Each command in a script is executed sequentially.
You can send hundreds of commands in a single script.

10) Message Command – Ethernet Only

Syntax: MESSAGE x<CR>
<CR> = carriage return

Description: This command will allow you to send a custom message to any new user that connects to the 50BA-001-63.

Examples: MESSAGE I will be using attenuators 1 and 2 on the 50BA-001-63 today (9/2) -CLK<CR>
Returns: "Message Stored<CR><LF>"
Then if a new user connects to the 50BA-001-63, they would see:
"Connection Open 50BA-001-63<CR><LF>"
"I WILL BE USING ATTENUATORS 1 AND 2 ON THE 50BA-001-63 TODAY (9/2)-CLK<CR><LF>"

-or if an IDN command is sent-

IDN<CR> Returns:
"JFW Industries Inc., Model 50BA-001-63, Firmware Rev 0 <CR> <LF>"
"Current Ethernet Connections = 2 <CR> <LF>"
"I WILL BE USING ATTENUATORS 1 AND 2 ON THE 50BA-001-63 TODAY (9/2)-CLK<CR><LF>"

Notes: "x" can be any ASCII string up to 100 characters long.
There must be a space between MESSAGE and "x".
This command is helpful for letting colleagues know you are using the test system for an important test and the attenuation settings must not be disturbed.
The Message can be cleared by sending the Clear command from any user connected in Ethernet mode.
Command is not case sensitive, but must be terminated by a carriage return.

11) Clear Command – Ethernet Only

Syntax: CLEAR<CR>
<CR> = carriage return

Description: This command clears the custom Message stored by the Message command.

Examples: MESSAGE I will be using attenuators 1 and 2 on 50BA-001-63 today (9/2)-CLK<CR>
IDN<CR> Returns:
"JFW Industries Inc., Model 50BA-001-63, Firmware Rev 0 <CR> <LF>"
"Current Ethernet Connections = 2 <CR> <LF>"
"I WILL BE USING ATTENUATORS 1 AND 2 ON 50BA-001-63 TODAY (9/2)-CLK<CR><LF>"

CLEAR<CR> Returns: "Message Cleared<CR><LF>"
IDN<CR> Returns:
"JFW Industries Inc., Model 50BA-001-63, Firmware Rev 0 <CR> <LF>"
"Current Ethernet Connections = 2 <CR> <LF>"

Notes: Command is not case sensitive, but must be terminated by a carriage return.

12) Store Command

Syntax: STORE<CR>
<CR> = carriage return

Description: This command will write the current attenuator settings to the onboard flash memory to be Recalled at a later time, even after power cycling the 50BA-001-63.

Examples: SAR 1 10<CR> Returns: "Atten#1 = 10 dB<CR><LF>"
RA1<CR> Returns: "Atten#1 = 10 dB<CR><LF>"
STORE<CR> Returns: "1 Attenuators Settings Stored In Memory<CR><LF>"

Notes: Please allow approximately 1 second to write the data to memory.
Command is not case sensitive, but must be terminated by a carriage return.

13) Recall Command

Syntax: RECALL<CR>
<CR> = carriage return

Description: This command reads the data stored on the onboard flash memory from the last Store command, and resets all of the attenuators to those settings.

Example: (Continuing From the STORE Command Example Above)

SAR 0<CR> Returns: "Atten#1 = 0 dB<CR><LF>"
RA1<CR> Returns: "Atten#1 = 0 dB<CR><LF>"

RECALL<CR> Returns: "1 Attenuator Setting Loaded From Memory<CR><LF>"
RA1<CR> Returns: "Atten#1 = 10 dB<CR><LF>"

Notes: Command is not case sensitive, but must be terminated by a carriage return.

14) Set Manual Speed Command

Syntax: SMSx<CR>
<CR> = carriage return

Description: This command changes the speed at which holding the momentary lever actuator switch on the front panel changes the attenuation.

Examples:	SMS10<CR>	Returns: "Manual Speed = 10/10<CR><LF>"
	SMS1<CR>	Returns: "Manual Speed = 1/10<CR><LF>"
	SMS5<CR>	Returns: "Manual Speed = 5/10<CR><LF>"
	SMS0<CR>	Returns: "Manual Speed = OFF<CR><LF>"

Notes: There must not be a space between "SMS" and "x".
"x" must be 0-10.
"x" = 10 corresponds to 100% speed.
"x" = 1 corresponds to 10% speed.
"x" = 5 corresponds to 50% speed.
"x" = 0 turns Manual Control OFF
"x" is saved to onboard flash memory and is restored after power cycling the unit.
The factory default value for "x" is 5.
Command is not case sensitive, but must be terminated by a carriage return.

4. Ethernet Mode

Overview

The 50BA-001-63 is Ethernet (TCP) controlled via a standard RJ-45 Ethernet connector on the rear of the unit. The controlling computer must establish a TCP connection to the test system. The remote command format and examples can be found in the “Remote Command Set” section of this manual. The command formats are the same for either Ethernet or RS-232 control. If commands are sent incorrectly to the unit, you will receive an error message.

The slide switch on the back panel allows the user to select between either Ethernet or RS-232 control. The unit must be turned off and then back on, when changing between Ethernet and RS-232 control for the change to take affect.

Multiple Ethernet Connections

The 50BA-001-63 allows the ability for multiple Ethernet connections at once. There can be up to 4 users connected to the test system simultaneously. All four users will connect to the test system using the same IP address and port number. The IP address can be configured to whatever the user requires. See the next section for details on configuring the IP settings. The port number is hard coded at 3001 and can not be changed.

The remote commands *Set Attenuator* and *Read Attenuator* are received and processed in less than 3 milliseconds. A user can stream *Set Attenuator* commands to the test system and there will only be a delay of a few milliseconds caused by the commands from other users.

Ethernet Configuration Information

This unit comes programmed to the following Ethernet settings:

I.P. Address **192.168.1.250**
Gateway **192.168.1.1**
Netmask **255.255.255.0**
Port **3001** (hard-coded into the unit and can not be changed)

An additional document “Sample Ethernet Configuration Session.PDF” comes with this manual and is located on the CD in PDF format. This sample session shows step by step example of how the Ethernet port is configured.

Open up a terminal session through your computer’s COM port using a program like HyperTerminal. You must use a Null Modem cable (JFW part #012-174) to make the physical connection from your COM port to the “Ethernet Config. Port” on the rear of the 50BA-001-63. The terminal session should use the following COM port settings:

Baud Rate: 9600
Data Bits: 8
Parity: None
Stop Bits: 1
Flow Control: None

You can verify a successful connection by typing “show” in the terminal window. You should receive an echo back from the 50BA-001-63. The commands listed below can then be used to change the network properties.

SHOW	Displays the Gateway setting
SHOW ETH0	Displays IP address and Netmask settings
SET IP xxx.xxx.xxx.xxx	Changes the I.P address
SET NETMASK xxx.xxx.xxx.xxx	Changes the Netmask
SET GATEWAY xxx.xxx.xxx.xxx	Changes the Gateway
SET NAMESERVER xxx.xxx.xxx.xxx	Changes the Nameserver

5. RS-232 Mode

This unit is RS-232 controlled via a standard 9-Pin D connector on the rear of the unit. The remote command format and examples can be found in the "Remote Command Set" section of this manual. The command formats are the same for either RS-232 or Ethernet control. If commands are sent incorrectly to the unit, you will receive an error message.

The baud rate can be set at 9600, 19200, or 38400. The current baud rate is displayed on the front panel by the LCD. To change to a different baud rate, the remote command "change baud rate" must be sent. This remote command is fully described in the "Remote Command Set" section of this manual.

The slide switch on the back panel allows the user to select between either RS-232 or Ethernet control. The unit must be turned off and then back on, when changing between Ethernet and RS-232 control for the change to take affect.

RS-232 Cable

Included with the system should be one "Null Modem" cable (JFW part #012-174). This cable is used to interface with the RS-232 Port. This cable is DE-9P to DE-9S and is the "Null Modem" type. The female connector will plug into the serial port on most PC's, and the male connector will connect to 50BA-001-63. This cable can also be bought from L-Com (L-Com #CSNULL9MF-10).

RS-232 Port Settings

When sending commands to the 50BA-001-63, your computer's RS-232 port settings must be configured as follows. The baud rate must be set at 9600, 19200, or 38400. The parity must be set to "none". The data length must be set to "8" data bits. The stop bit must be set to "1". If your RS-232 port is not configured with these settings, the 50BA-001-63 will not receive and execute the commands sent. It will not send back an error either, because communication was never established.

BAUD RATE	9600
PARITY	none
DATA LENGTH	8 bits
STOP BITS	1
FLOW CONTROL	none

6. JFW Test Program

IMPORTANT NOTE: No installation program needs to be run in order to use the JFW test program. Just copy the executable file and library directory located on the CD that is provided with this manual onto any location on your computer.

While using the program, you will see the commands you send displayed in the “Data Sent” window and any response from the test system in the “Data Received” window. In addition to the 50BA-001-63's remote command set, JFW has provided the following functionality to the GUI:

GUI Typed Command

Allows you to send any ASCII message you want to the test system. Just type your message in the text box and click on the Send Message button. Your Message is displayed in the “Data Sent” window.

GUI Keypress Attenuator

Allows you to easily step attenuation up or down for a specific attenuator number.

50BA-001-63 - www.jfwindustries.com

50BA-001-63 Test Software (Rev 0)

RS-232 Setup ?

Close RS-232 Port

Com Port: COM3

Baud Rate: 9600

Ethernet Setup ?

Connect Ethernet

IP Address: 192.168.1.240

Port Number: 3001

Ethernet Configuration

Remote Commands

Set Attenuator dB: 0

with Response

Fade Attenuator

Read Attenuator

Change Baud Rate

Set Manual Speed

GUI Handover Testing

GUI Handover

GUI Indefinite Handover

GUI Keypress

Keypress Start at dB: 0

Step by dB: 1

GUI Typed Commands

Send Message

IDN

Clear Text Clear Drop Down Box

Data Sent

Clear Text

Data Received

Clear Text

More information available at: www.jfwindustries.com

GUI Handover Window

1) Overview

The GUI handover window sends the *Set Attenuator* remote commands at specified intervals to the test system in order to change the attenuation settings. The *Set Attenuator* remote command is described in the *JFW Command Set* of this manual. The *Set Attenuator* remote command is the only remote command used by the GUI program in this window. All other actions by this window are part of the GUI program code.

IMPORTANT NOTE: It is possible for the GUI program to send remote commands faster than the test system can process the commands. Click the *Minimum Interval Times* button on the GUI Handover window for a listing of interval times versus number of attenuators checked.

2) Handover Tests

This window can be used to perform handover testing. Set the interval time between attenuation changes at the top of the window. Click the check box to make each slider bar active. Click the *Start* button at the top of the window. The slider bar will begin moving and sending remote commands to the test system. The current attenuation setting of each attenuator is listed and updated as the attenuation changes. When the attenuation level reaches the “Stop at dB” value, then the slider bar will stop moving.

3) Quick Setting Attenuation Settings

This window can also be used for quick manual setting of attenuation levels. The slider bar can be controlled using the mouse pointer, mouse wheel, or left/right arrow keys. When the slider bar is moved, the new attenuation value is displayed next to the attenuator number.

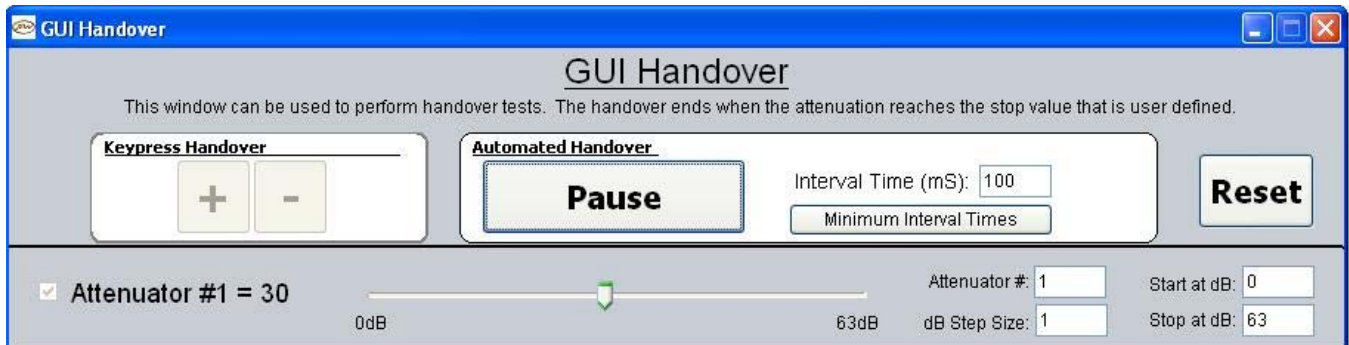

GUI Indefinite Handover Window

1) GUI Indefinite Handover Window Vs. GUI Handover Window

This window is very similar to the GUI Handover window. The GUI Handover window slider bar stops moving when the attenuation level reaches the “Stop at dB” setting. The GUI Indefinite window slider bar doesn’t stop moving until the user clicks the “stop” button at the top of the window. The slider bar will continue to oscillate between the “Start at dB” and “Stop at dB” settings until the user stops it. That is the only difference between the two windows.

IMPORTANT NOTE: It is possible for the GUI program to send remote commands faster than the test system can process the commands. Click the *Minimum Interval Times* button for a listing of interval times versus number of attenuators controlled.

2) Quick Setting Attenuation Settings

This window can also be used for quick manual setting of attenuation levels. The slider bar can be controlled using the mouse pointer, mouse wheel, or left/right arrow keys. When the slider bar is moved, the new attenuation value is displayed next to the attenuator number.



7. Scripts

Script FAQ's

1) **What is a script?**

A script is a text file (.txt) that lists multiple remote commands. Notepad for Windows can be used to generate the text files. Terminal programs such as Hyperterminal for Windows can be used to send the text file to a test system via Ethernet or RS-232.

2) **Why would I want to use scripts?**

You have a test that will be run repeatedly and it uses the same remote commands each time. Using a script saves you from having to type in the same set of remote commands over and over.

3) **How does the JFW test system execute a script?**

All remote commands listed in a script are executed sequentially. When you send the script the terminal program lists all of the remote commands sent in the terminal window. The JFW test system stores all of the commands in a receive buffer. It reads the first command and executes the command. Only when the first command is fully executed does the test system delete the command from the buffer to make room for more commands to be sent, and then begin processing the next command. Each command is read in and executed sequentially until all of the commands in the receive buffer are gone.

4) **How many remote commands can be in one script?**

JFW has tested scripts on Ethernet test systems and RS-232 test systems that contain as many as 1000 remote commands in a single script. It also depends on what commands are being sent. Timed commands like Pause, Fade, and Variable Handover can lower this number based on their durations.

5) **What happens if I send a second script before the first script is completely processed?**

The commands contained in the second script will be seamlessly processed after all of the commands in the first script have been executed.

6) **How do I terminate each remote command in my text file with a carriage return?**

When you use the "enter" key to go to the next line it will include a carriage return and line feed in the text file. This means that each line of the text file should contain only one remote command.

7) **Why does the last remote command in my script does not execute?**

The last command is not properly terminated with a carriage return. You must press the "enter" key at the end of the last remote command to add a carriage return in the text file.

8) **Why is my script is not finishing and/or locking up the 50BA-001-63?**

The buffer size of the 50BA-001-63 is 1200 characters. This means that timed commands like Pause, Fade, or Variable Handover can delay this process. If your script uses these and you are trying to send more than 1200 characters after it, the buffer will overflow and can crash the firmware. We have implemented a GUI Script Management window in our 50BA-001-63.EXE test program to help address this issue. Since many of these long scripts are repetitive, the GUI Script Management screen allows you to send a smaller script, but multiple times so it is not all sent at once. It also allows you to control how often each script is sent and calculate its duration.

Script Example

Step 1: Generate the Text File

For this example Notepad for Windows was used to generate the below text file. Every remote command is listed on a single line so that there is a carriage return terminating each remote command.

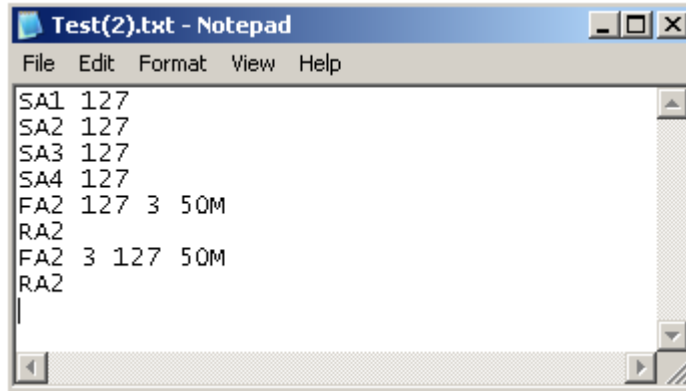

Step 2: Connect to the Test System

Hyperterminal for Windows was used to establish an Ethernet connection with the test system.

Step 3: Send the Text File

Select “Send Text File” from the Transfer tab.

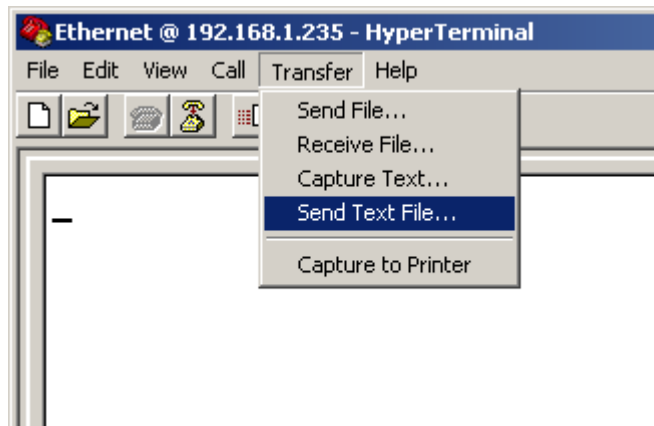

Step 4: Select the Text File

HyperTerminal prompts you to select your text file.

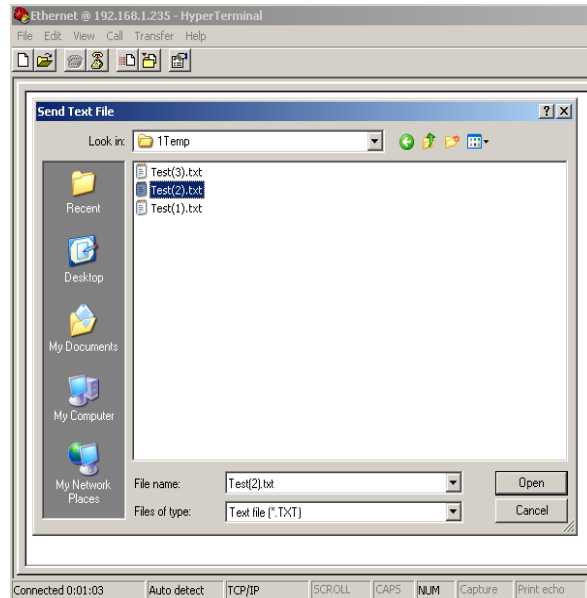

Step 5: Waiting for the Remote Commands to be Processed

The remote commands in the text file are sent and listed in the terminal window. Each command is executed sequentially until there are no more remote commands in the receive buffer. The “3dB” text does not show up until the first read attenuator command (RA2) is complete. The “127dB” text does not show up until the second read attenuator command (RA2) is complete.

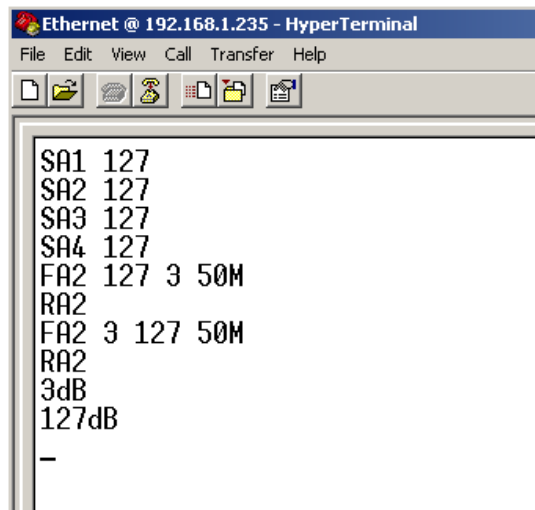

GUI Script Manager (50BA-001-63.EXE Test Software)

Purpose

The Script Management screen allows you to send long complicated scripts to the 50BA-001-63 from the test software. You can write your own in a text editor or directly into the “Script To Send” window. Traditionally, if you were sending a script through a Telnet service like Hyperterminal as previously described, it sends the entire script all at once. If the script is very long however, this may overflow the buffer in the 50BA-001-63 and cause it to crash or lockup. Since many of these kind of long scripts are repetitive, the Script Management window allows a user to send a smaller script, but multiple times, and control how often to send it so that it does not overflow the receive buffer of the 50BA-001-63.

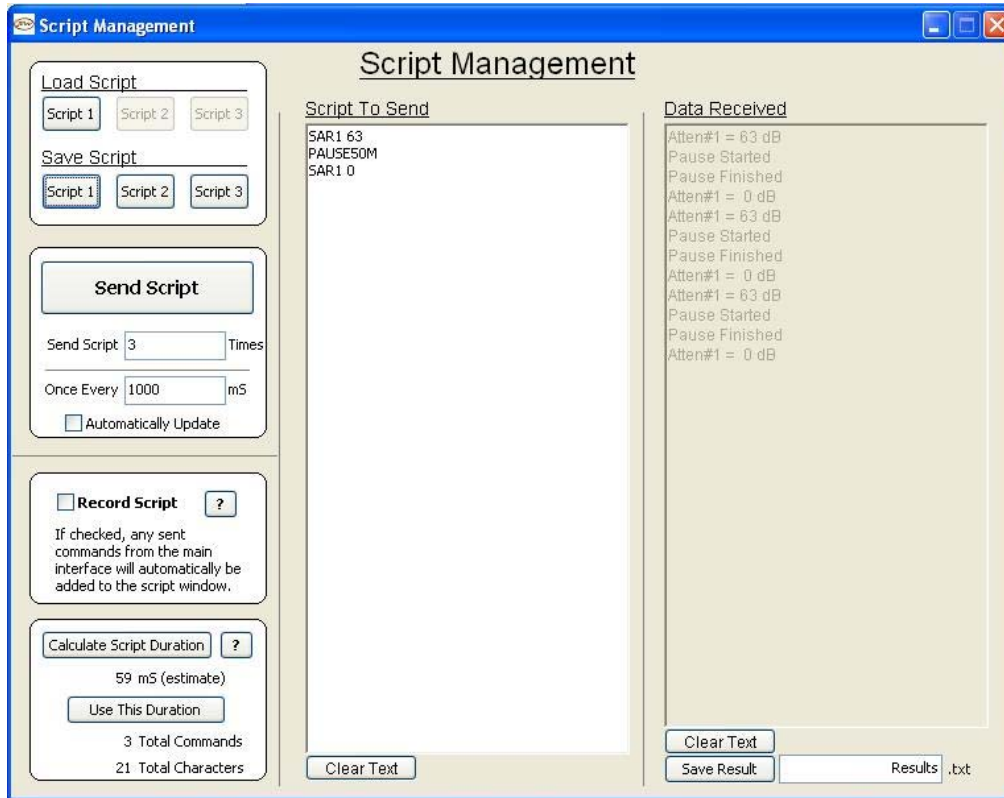

Saving and Loading Scripts

The Script Management window supports up to three unique scripts, which must be in the same directory as the test program, and named the following: Script1.txt, Script2.txt, and Script3.txt. You can then load these txt files into the Script To Send window, and also edit them from there. To save any changes made to a script, you will still need to Save it with one of the Save Script buttons.

Recording Scripts

Recording a script is helpful if you cannot remember the exact command format for a particular command and also eliminates typing errors from entering them manually. By selecting the “Record Script” checkbox, all commands sent from the rest of the test program will, instead of sending the commands to the 50BA-001-63, be sent to the “Script To Send” window. Commands may still be entered in the “Script To Send” window manually if you prefer.

Calculate Script Duration

This feature calculates the entire length of the script in the “Script To Send” window in milliseconds. This accounts for 3 milliseconds of processing time for each command, as well as all Pauses, Fades, and Variable Handovers formatted in either Seconds or Milliseconds.

8. FAQ's

If you are reading this page because you are having problems with a JFW test system, please contact JFW at **317-887-1340** or **sales@jfwindustries.com**. One of our engineers would be more than happy to help you troubleshoot the unit and get you back on track.

How do I find out the revision level of my firmware?

Right after the unit is powered on, the firmware revision level is displayed on the LCD. The firmware revision level is also included with the information sent back from an “identification” remote command.

I just switched from Ethernet mode to RS-232 mode using the switch on the back panel, but I am still in Ethernet mode. Why did the mode not change?

You must turn the unit off and then back on for the change to take affect.

Why won't the unit respond to my Ethernet commands?

Verify the following settings: IP address, Gateway, Netmask, and Port Number. Remember that the Port Number is hard-coded to 3001 and can not be changed. Check you command format in the “Remote Command Set” section of this manual.

Why is the unit not responding to my Ethernet port configuration commands?

The Ethernet is configured using the “Ethernet Config. Port” on the back panel. It is a RS-232 port. You must use a Null Modem type RS-232 cable. You must use the following RS-232 port settings with this port: baud rate (9600), data bits (8), parity (none), stop bits (1), flow control (none).

Why won't the unit respond to my RS-232 commands?

Verify the following RS-232 settings: baud rate, parity (none), data bits (8), and stop bits (1). The current baud rate is displayed on the front panel by the LCD. Check you command format in the “Remote Command Set” section of this manual.

Why don't I get a response from the unit when I send the remote command “RA1”?

All remote commands must be terminated with carriage returns. Attach a carriage return to your command string right after the “9”.

I sent a remote command and received back “Error1”. What does “Error1” mean?

This error occurs if characters other than IDN, CB, SA, or RA appear in the buffer. A complete list of error codes is listed in the “Remote Command Set” section of this manual.



Appendix A

Sample Ethernet Configuration Session

JFW Industries, Inc.
5134 Commerce Square Drive
Indianapolis, Indiana 46237
phone 317-887-1340
sales@jfwindustries.com

Introduction

Before using the JFW system, the Ethernet Port of the JFW system must be configured for use on your network. You must assign a unique IP address, Gateway address, and Netmask address. Connect the null modem serial cable (Ethernet Configuration Cable listed in manual) supplied with the unit from the “Ethernet Configuration Port” (back panel of system) to the serial port (RS-232 port) of your computer.

Power system unit on, and run a terminal program on your computer (such as Hyperterminal for Windows). The serial settings of Hyperterminal should be 9600 baud, 8 data bits, parity set to NONE, 1 stop bit, and flow control set to NONE as seen in picture below.

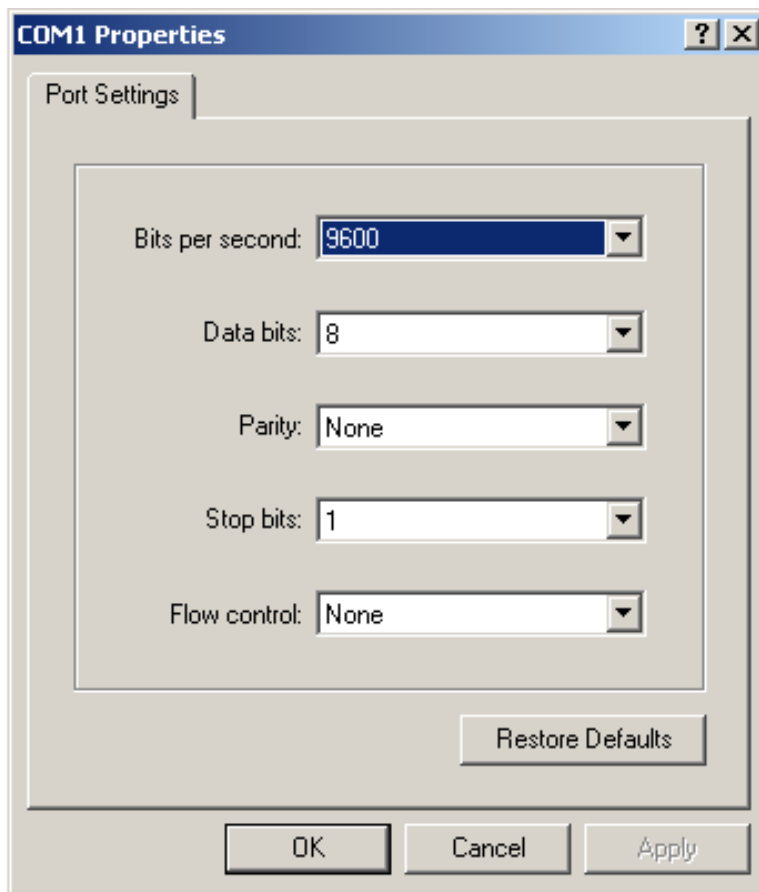

The 50BA-001-63.EXE Test Program also supports Ethernet Configuration. This is described at the end of the Hyperterminal example.

Sample Ethernet Configuration Session

The current settings are:

IP address	192.168.1.222
Gateway	192.168.1.2
Netmask	255.255.255.2
Port	3001 (hard-coded in system and can't be changed)

The new settings will be:

IP address	192.168.1.250
Gateway	192.168.1.1
Netmask	255.255.255.0
Port	3001 (hard-coded in system and can't be changed)

Step 1: Turn off the power to the test system.

Step 2: Position the Ethernet mode/RS-232 mode slide switch on the back panel to Ethernet mode.
(For Ethernet only test systems, just skip to step 3.)

Step 3: Turn on the power to the test system. The test system is now in Ethernet mode.

Step 4: Connect the Null modem cable from you computer's serial port to the port on the test system labeled "Ethernet Config. Port".

Step 5: Open a terminal program (such as Hyperterminal for Windows) and configure the serial settings to 9600 Baud, 8 data bits, no parity, 1 stop bit, no flow control.

Step 6: You are now ready to send commands to configure the Ethernet port.

Note: All following text that is colored blue and bold is text that you type.
All following text that is colored red and bold is a keystroke that you make.
(The PDF file of this document located on the CD for this system is in color)

help <enter>

TCP/IP User Block Console Version 1.1

Available commands: (type "help <command>" for more info)

echo	- Turn on or off echoing of characters.
set	- Configure various options.
add nameserver	- Add a nameserver to the current l
mail	- Send an e-mail.
show	- Show current configuration.
help	- This help screen.

OK

show <enter>

Current Configuration:
I/O Parameter: 9600
Gateway: 192.168.1.2
Name Servers:
Mail Server:
Mail From: user@somewhere.com

Interfaces: ETH0

OK

show eth0 <enter>

Current ETH0 Configuration:

Status: up
IP Address: 192.168.1.222
Netmask: 255.255.255.2
MTU: 600
Ping Config: off
Ping Config Done: no

OK

set ip 192.168.1.250 <enter>

IP address set to: 192.168.1.250

OK

set netmask 255.255.255.0 <enter>

Netmask set to: 255.255.255.0

OK

show eth0 <enter>

Current ETH0 Configuration:

Status: up
IP Address: 192.168.1.250
Netmask: 255.255.255.0
MTU: 600
Ping Config: off
Ping Config Done: no

OK

show <enter>

Current Configuration:

I/O Parameter: 9600
Gateway: 192.168.1.2
Name Servers:
Mail Server:
Mail From: user@somewhere.com
Interfaces: ETH0

OK

set gateway 192.168.1.1 <enter>

Gateway set to: 192.168.1.1

OK

show <enter>

Current Configuration:

I/O Parameter: 9600
Gateway: 192.168.1.1
Name Servers:
Mail Server:
Mail From: user@somewhere.com
Interfaces: ETH0

OK

Ethernet Configuration with JFW Test Software

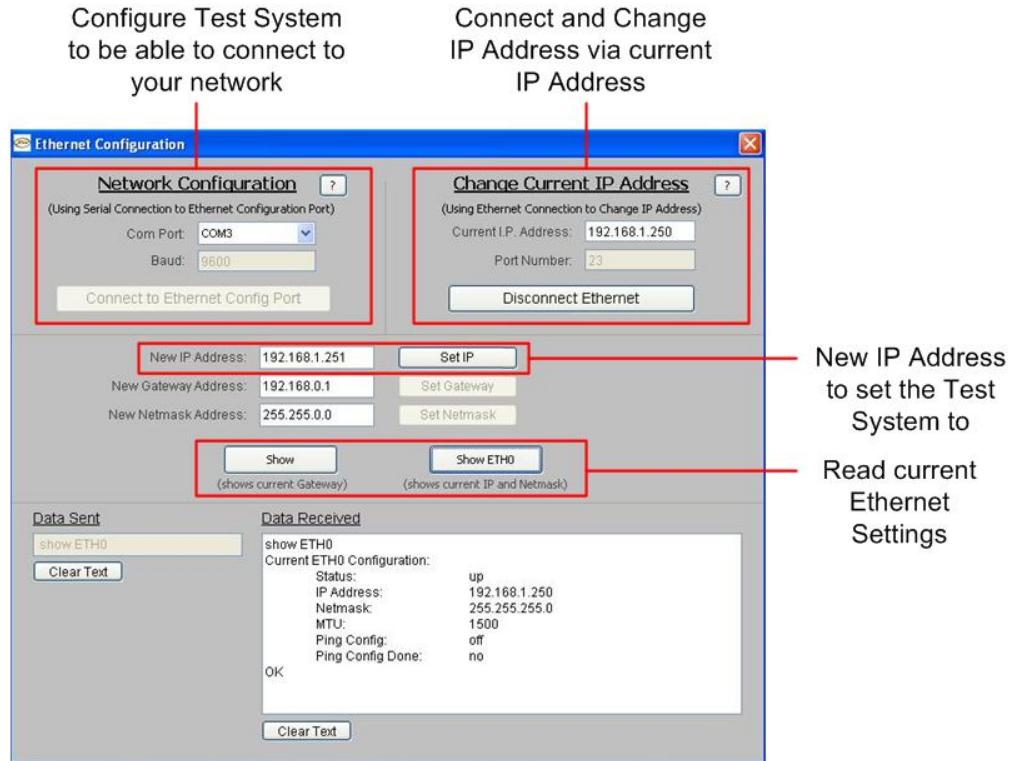

Ethernet Configuration can be done using the provider JFW Test Software as well. The Ethernet Mode and Remote Command Set for the 50BA-001-63 is tested here at JFW on our own internal network. We use a standard 192.168.1.1 network so depending on your own network settings, you may not immediately be able to connect to the test system.

If this is the case you will first need to change the network settings of the 50BA-001-63 serially via the “Ethernet Config” port on the rear panel of the unit.

- 1) Open the Ethernet Configuration window of the test program, located below the Ethernet Connection section.
- 2) From here, select the COM Port you have connected to the “Ethernet Config” RS-232 connector on the rear panel in the drop-down box under Network Configuration, and click “Connect to Ethernet Config Port”
- 3) The three Set buttons should activate, allowing you to now reprogram the IP Address, Gateway, and Netmask below. The Show and ShowETH0 buttons allow you to read the current settings of the 50BA-001-63.
- 4) Once the Gateway and Netmask have been programmed to your network, you should be able to connect to the 50BA-001-63 at the IP you selected. At this point you may change the IP address via Ethernet by connecting to it on port 23 under the Change Current IP Address section. Only the IP address can be changed via Ethernet however.



Appendix B

Startup Information For Ethernet/RS-232 Test Systems

JFW Industries, Inc.
5134 Commerce Square Drive
Indianapolis, Indiana 46237
phone 317-887-1340
sales@jfwindustries.com

Below is some basic information that you will need to know in order to operate your JFW test system. Refer to the test system manual for more detailed information. If you have any problems getting the test system up and running, please contact JFW (317-887-1340, sales@jfwindustries.com) and one of our engineers will assist you.

Changing from RS-232 mode to Ethernet mode

1. Turn off power to the test system.
2. Change the position of the slide switch (on back panel) from RS-232 mode to Ethernet mode.
3. Turn on power to the test system. The display on the front panel will display “Ethernet Mode”.

Ethernet Config. Port

1. The “Ethernet Config. Port” is only used while the test system is in Ethernet mode.
2. This port will only process the Ethernet configuration commands (i.e. set ip, set gateway, set netmask).
3. This port will NOT process the JFW command set (i.e. set attenuator, read attenuator, identification).
4. For a step by step guide to configuring the Ethernet port, refer to the document “Sample Ethernet Configuration Session”. Also, the test system manual has a section that covers Ethernet configuration.

Ethernet Port

1. The “Ethernet Port” is only used while the test system is in Ethernet mode.
2. This port will only process the JFW command set (i.e. set attenuator, read attenuator, identification).
3. This port will NOT process the Ethernet configuration commands (i.e. set ip, set gateway, set netmask).
4. The test system manual has a complete list of the JFW command set.

RS-232 Port

1. The “RS-232” is only used while the test system is in RS-232 mode.
2. This port will only process the JFW command set (i.e. set attenuator, read attenuator, identification).
3. This port will NOT process the Ethernet configuration commands (i.e. set ip, set gateway, set netmask).
4. The test system manual has a complete list of the JFW command set.