

SMA FEMALE
7-PLACES

6-32 x .125 DP
4-PLACES

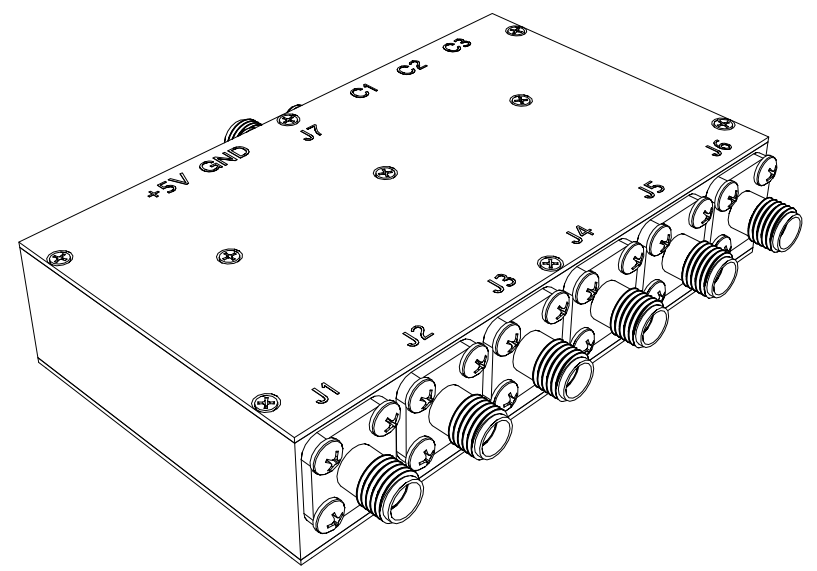

J7 TO	C1	C2	C3
ALL OFF	0	0	0
J1	1	0	0
J2	0	1	0
J3	1	1	0
J4	0	0	1
J5	1	0	1
J6	0	1	1

REV	ECN	DATE	BY	APPR
-	ISSUED	8-10-88	-	FDW
A	2864	4-4-90	PT	FDW
B	2973	6-29-90	TEZ	FDW
C	3708	8-11-92	TEZ	FDW
D	6989	1-28-02	CMB	TEZ
E	7026	3-5-02	MAH	TEZ
F	16167	8-1-08	BZ	TEZ
G	20988	12-12-11	JZ	BAC
H	24444	11-25-15	JZ	TEZ

JFW INDUSTRIES, INC.

www.jfwindustries.com PH: 317-887-1340

MATERIAL	ALUMINUM ALLOY	PROPRIETARY INFORMATION
FINISH	SILVER	ALL SURFACES ARE TO BE FREE OF BURRS, PITS & SCRATCHES
MODEL	50S-XXXX	TOLERANCES .XX±.010 .XXX±.005 XX°±.5°
DESCRIPTION	1P6T COAX. SWITCH	DWG # 092-1178