

J3 TO:	C1	C2
J1	1	0
J2	0	1
OFF	0	0

OR

J3 TO:	C1 OR C2
J1	0
J2	1

50S-581 / 773 / 855 / 1228 ONLY

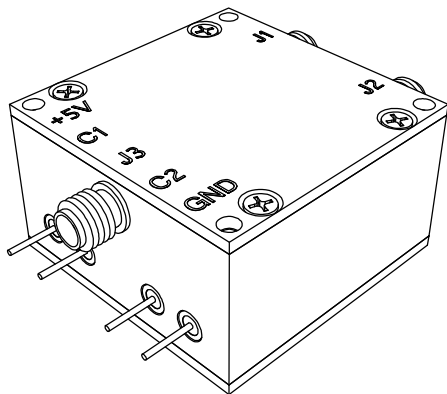

REV	ECN	DATE	BY	APPR
-	ISSUED	12-3-87	PT	FDW
A	3547	2-18-92	PT	FDW
B	3951	5-6-93	TEZ	FDW
C	4267	6-15-94	TEZ	FDW
D	5719	6-23-98	CDJ	FDW
E	5728	7-1-98	CDJ	FDW
F	6884	10-25-01	TEZ	TEZ
G	6989	1-28-02	CMB	TEZ
H	20416	8-5-11	JZ	TEZ
J	24444	12-2-15	JZ	TEZ



JFW INDUSTRIES, INC.

www.jfwindustries.com

PH: 317-887-1340

MATERIAL	ALUMINUM ALLOY	PROPRIETARY INFORMATION
FINISH	SILVER	ALL SURFACES ARE TO BE FREE OF BURRS, PITS & SCRATCHES
MODEL	50S-XXX	TOLERANCES .XX±.010 .XXX±.005 XX°±.5°
DESCRIPTION	1P2T COAX. SWITCH	DWG # 092-1051