

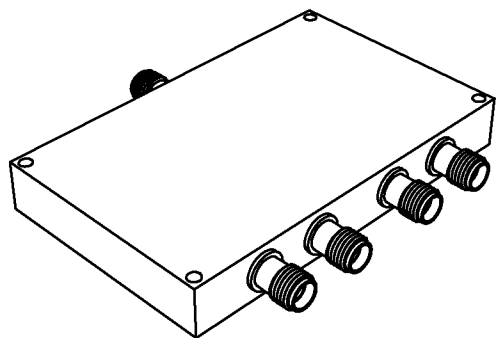

NOTE: DIMENSIONS ARE IN INCHES [MILLIMETERS]



REV	ECN	DATE	BY	APPR	 JFW INDUSTRIES, INC. www.jfwindustries.com PH: 317-887-1340	
-	ISSUED	2-19-08	BZ	TEZ	MATERIAL ALUMINUM ALLOY PROPRIETARY INFORMATION	
A	24444	10-5-15	JZ	TEZ	FINISH GRAY EPOXY PAINT ALL SURFACES ARE TO BE FREE OF BURRS, PITS & SCRATCHES	
					MODEL 50PD-XXX	SCALE FULL TOLERANCES .XX±.010 .XXX±.005 XX°±.5°
					DESCRIPTION 4 WAY POWER DIVIDER / COMBINER	DWG # 092-5727